



GB



Service Manual

Compact 3010



CE



FOREWORD

This service handbook is intended to assist with servicing and fault-finding in caravans and motor caravans equipped with the Alde Compact 3010. The handbook may also be of assistance in ordering spare parts.

It also provides general information on how Alde central heating systems are designed, and how they operate.

When servicing components designed for LPG and 230 volts, national safety regulations must be adhered to.

After the boiler has been serviced, the service record must always be completed.

Alde International Systems AB

Service Department

NB! We reserve the right to make changes after this handbook has been printed.

CONTENTS

Page	Chap	Designation
3	1:0	About the Alde central heating system
4	1:1	Maintaining the heating system
4	2:0	About the Compact 3010
4	2:1	How the heater works
5	2:2	The LPG boiler
5	2:3	Technical data
6	3:0	Replacing components
6	3:1	Replacing the printed circuit board
6	3:2	Replacing fan
7	3:3	Replacing a burner

Page	Chap	Designation
7	3:4	Replacing spark electrode
7	3:5	Replacing flame sensor
8	3:6	Replacing solenoid valve
8	3:7	Replacing sensor
9	4:0	Fault messages in the panel
9	5:0	Safety checks
10	6:0	Exploded diagram
11	6:1	Article numbers on exploded diagram
12	7:0	Electrical diagram with control panel
13	8:0	Spare parts

1:0 ABOUT THE ALDE CENTRAL HEATING SYSTEM

The central heating system uses two or three heat sources – an LPG boiler and a 230 volt electrical heating cartridge, as well as an externally-fitted heat exchanger for motor caravans. The LPG boiler/heating cartridge heats up a liquid mixture consisting of water (60%) and glycol (40%). With the aid of a 12-volt circulation pump, which is located in an expansion vessel, the warm glycol/water mixture is circulated round the system through pipes and convectors.

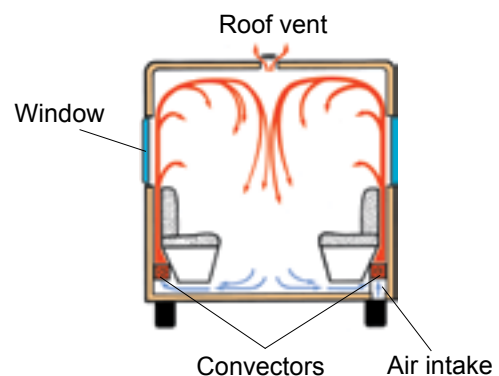
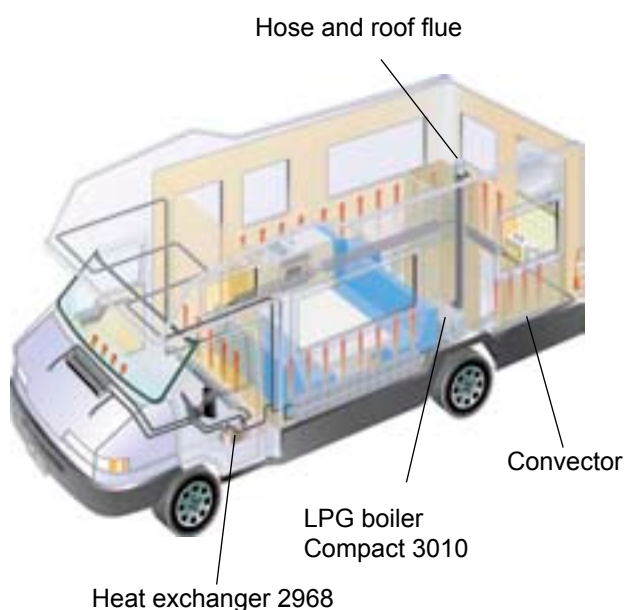

The convectors, which are fitted along the outer walls, heat up the air, which rises and warms the walls and furniture. As the warm air rises, it forms an air-barrier which prevents cold from the windows entering. The temperature inside the caravan is controlled by a 12-volt thermostat on the control panel.

1:1 MAINTAINING THE HEATING SYSTEM

Check the heating system's fluid level regularly in the expansion vessel. The level should be approximately 1cm above the Min mark when the system is cold. The heating system should be filled with a mixture of water and glycol. For preference, use high quality pre-mixed glycol (with inhibitor) intended for use in aluminium heating systems.

If using concentrated glycol, the mixture should consist of 60% water and 40% glycol. If the heating system will be exposed to temperatures below -25°C , the glycol content must be increased, but not to more than 50%.

Any vessels used in handling the liquid must be spotlessly clean, and the pipes in the heating system must be free of contamination. This will prevent the growth of bacteria in the system. The glycol mixture should be changed every second year, since its ability to protect against corrosion, for example, will deteriorate. The glycol content should be checked before topping up with new liquid. This will ensure that the concentration of glycol in the mixture is not too high.

If the fluid level in the expansion tank falls for reasons other than evaporation, check all joints, drain cocks and bleeder screws to ensure that they are not leaking. If the glycol-water mixture leaks out, rinse with water and wipe up.

Never allow the heating system to stand empty of glycol fluid.

Adding liquid:

Ensure that the vehicle is standing level, and check that the bleeder screws and drain cocks are closed. Release the plastic nut on the circulation pump, located on the expansion vessel, and lift out the pump. Pour the glycol mixture slowly into the expansion vessel, using a watering can. When the system is being filled, air pockets may form, depending on how the pipe-system has been installed. A good indication that there is air in the system is when the heat only travels a few metres along the pipe from the boiler, despite the fact that the circulation pump is operating.

To make refilling and bleeding easier, we recommend using the Alde filling pump which quickly both fills and bleeds the system automatically.

Bleeding a caravan heating system (manually):

The LPG boiler must be switched on and the circulation pump switched off. Start by opening the bleeder screws (please refer to the vehicle instruction book for their location). Leave them open until liquid escapes through the spout at the air screw. Switch on the circulation pump and let it run for a while. Check whether the pipes and radiators all around the caravan are warm.

If air still remains in the system, try the following:

The LPG must be switched on and the circulation pump switched off. Lower the front of the caravan as far as possible using the jockey wheel. Leave it in this position for several minutes, to allow any air to rise to the highest point in the system. Open the bleeder screw at the highest point and keep it open until all the air has escaped.

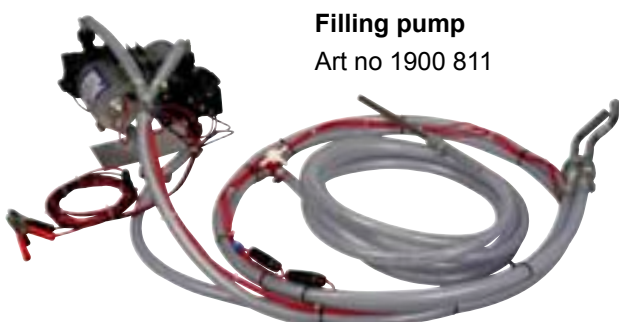

Filling pump
Art no 1900 811

Then raise the front of the caravan as high as possible using the jockey wheel, and repeat the process.

Return the caravan to a horizontal position and start the circulation pump.

Check that the heat is circulating all around the caravan. When bleeding a trailer or a motor caravan, it is easier to park on a steep slope, or raise the vehicle using a jack.

2:0 ABOUT THE COMPACT 3010

The set-up of the boiler.

The boiler consists of three eccentrically-fitted pipes. The innermost pipe is a heat exchanger made from extruded aluminium. This is surrounded by a water jacket containing a 40% glycol mixture which is the fluid for the heating system.

The fresh-water heater is located outside the water jacket. The two outer pipes, as well as their ends and connections, are made from stainless steel.

The heat exchanger is divided into two semicircular parts by a u-shaped baffle plate.

The burner is located in the upper semicircle, the combustion chamber. The baffle plate leads the flue gases back into the lower part of the section, which constitutes the convection part.

The burner housing is fitted on the end of the heat exchanger. On the burner housing is a fan, burner, solenoid valve and intake/exhaust connections. The exhaust gases escape through the inner tube, and fresh air enters through the outer tube. The exhaust fumes exit the vehicle via a hose and flue fitted either to the roof or to the wall. Fresh air enters via the same flue (balanced draft).

2 electrical heating cartridges are fitted to the upper part of the water jacket. The maximum output of the cartridges is either 2kW or 3kW depending on boiler model.

2:1 HOW THE BOILER WORKS

The boiler is a combined unit for producing heat and hot water. Electricity, LPG or a combination of both are used as energy source. The electrical elements, of which there are two, have an output of 1kW and 2kW respectively. The output is controlled via a relay on a printed circuit board, and depending on the model of the card, the maximum output is 2kW or 3kW respectively. When starting, not all the power is connected in at the same time, but connecting-in goes in two or three steps with a few seconds delay between them. The LPG heater has a burner that works in two steps. The lower of the two steps is 3kW, and the higher is 5.5kW. The power step that the heater works on is determined by the requirement for heat in the vehicle. Functions are also connected to the printed circuit board that are required for monitoring and controlling the heater.

They can be divided into the following units:

- Monitoring and regulating the speed of the fan at the two different power steps.
- Opening the different power steps of the gas valve at the right point of time. The ignition sparks the burner via the two spark electrodes mounted on the burner.
- Monitoring of the flame through ionised sensing via flame sensor pin mounted on the burner.
- Control and monitoring of radiator temperature via sensor mounted on the boiler body.
Control of warm water temperature via sensor mounted on the heater.
- Regulation of room temperature in the vehicle via sensors in the panel or sensors connected to the panel.

2:2 THE LPG BOILER

Starting

When the gas heater receives the signal to start, the system commences with an auto-check period in which the fan starts up at constant voltage and works at a speed of about 3000 rpm. If the speed is within the tolerance at the end of the period, a spark is generated, the solenoid valve opens the first step for gas, and the speed of the fan reduces to 2150 rpm. When the burner ignites, the electronics receive a signal via the sensor, the ignition ceases and the burner burns at step 1 for at least one minute before going over to the second power step if the need for heat so requires.

If the burner does not ignite within 10 seconds after the gas valve has opened, the attempt to start is discontinued and a new cycle commenced. If this also does not succeed, no further attempts to start will be made, and the text "GAS OUT" will be shown in the panel. In order to reset the boiler, gas must be shut off on the panel and switched on again.

Operation

When the burner is working, the flame is monitored via the flame sensor pin. If the flame goes out, the signal from the sensor is broken and the gas supply is shut off within 1 second. After that, the heater attempts to start in accordance with the description given above.

The burner fan speed is also continuously monitored when in operation. At step 1, the fan speed is 2150 ± 250 rpm and at step 2 it is 3200 ± 250 rpm. If the fan speed goes down to less than 2950 rpm, the heater changes down to step 1, and if the fans speed slows again so that it is below the permitted speed, the heater is completely switched off and the text "FAN" is shown in the display. In order to reset, it is necessary for the main current to the boiler to be broken and then switched on again.

Changing between power steps

The heater always ignites at step 1. In changing from step 1 to step 2, the fan speed increases from 2150 to 3200 rpm over in 2.5 seconds. When the fan speed exceeds 2600 rpm, the gas valve opens for step 2, while step 1 is kept open all the time. In order to open the gas valve's step, the electronics send 12 volts to each respective coil's opening circuit for 1 to 2 seconds. After this, the valve is kept open using the holding circuit. The opening circuit has a current consumption of about 1.5A, while the holding circuit's current consumption is only about 0.05A.

Regulation

The temperature in the vehicle is regulated with respect to the difference between the actual temperature within the vehicle and the required temperature set in the panel (Δt).

If electricity of 3kW + gas has been selected, the heater regulates as follows:

Δt	Function
+0.7°C	Pump 33 % El. 1 kW
+0.5°C	Pump 66 % El. 2 kW
+0.0°C	Pump 100% El. 3 kW
-0.5°C	Pump 100% El. 3 kW Gas step 1 33%
-1.0°C	Pump 100% El. 3 kW Gas step 1 66%
-1.5°C	Pump 100% El. 3 kW Gas step 1 100%
-2.0°C	Pump 100% El. 3 kW Gas step 1 100% step 2 33%
-2.5°C	Pump 100% El. 3 kW Gas step 1 100% step 2 100%

If, for example, only gas has been selected in the panel, the step for electricity goes out and gas step 1 33% comes in at the top of the regulation.

The maximum radiator temperature when the circulation pump is running is 82°C. When the circulation pump stops, the maximum temperature is 75°C.

Warm water

The heater continuously keeps warm water at a basic temperature of about 50°C. If the temperature goes down below this level, the heater increases power to a level in accordance with the control steps above. This may mean the temperature rising somewhat within the vehicle, which in turn means that the pump stops and the heater goes over to only generating warm water for a period of time.

If there is no need for heat, but the boiler is only working to generate warm water, the heater works on the electrical power selected; if only gas has been selected, the heater works at gas step 1.

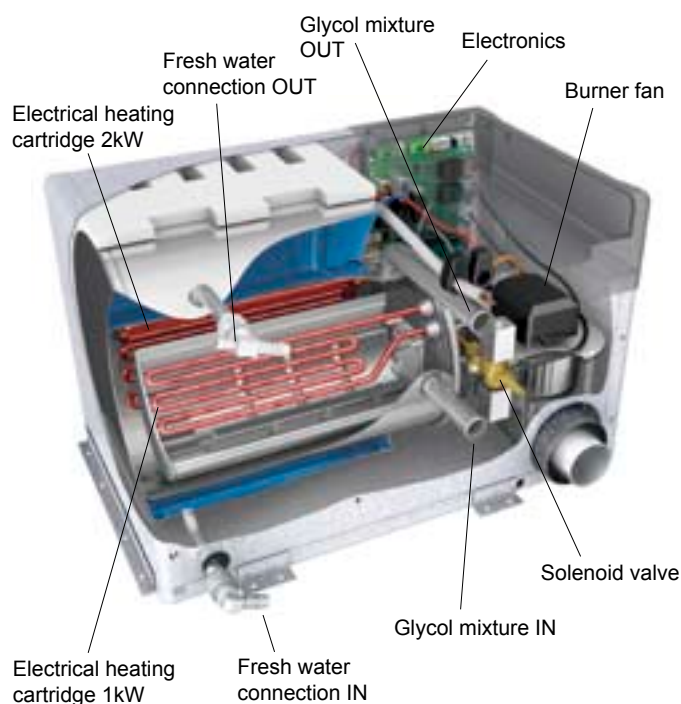

2:3 TECHNICAL DATA

Measurements:	Height	Width	Length
Boiler size:	305 mm	340 mm	490 mm
Rec. Min. installation dimensions:	310 mm	400 mm	500 mm

Weight: 14 kg (without liquid)

Gas:	Propane	Butane
Output step 1:	3,3 kW	3.8 kW
Consumption:	245 g/h	275 g/h
Output step 2:	5,5 kW	6,4 kW
Consumption:	405 g/h	460 g/h
Gas pressure	I_{3+} 28-30/37 mbar $I_{3B/P}$ 30 mbar	

Liquid volume/Pressure

Liquid volume, glycol mix:	3,5 liter
Liquid volume, fresh water:	8,4 liter
Max pressure, heating system:	0,05 MPa (0,5 bar)
Max pressure, fresh water:	0,3 MPa (3,0 bar)
System temperature:	max 85°C.

230 V ~

Output element :	1 x 1050 W
(2 or alternatively 3 kW)	1 x 2100 W

12 V DC

Current consumption:	1 amp (max)
Fuse:	3,15 amp+/3,15 amp-

3:0 REPLACING COMPONENTS

Always switch off the 12 V DC and 230 V ~ power supply, and turn the main gas cock to the off position before starting any servicing. The seals (marked in red) must NOT be broken unless special permission has been obtained from Alde.

3:1 REPLACING THE PRINTED CIRCUIT BOARD

1. Remove the service panel on the boiler.
2. Detach the blue cable (marked Blue)(fig.1A) and brown cable (marked Brown)(fig.1B), red cable (marked Red)(fig. 1C), grey cable (marked Grey)(fig. 1D) and black cable (marked Black)(fig. 1E) on the printed circuit board, and the blue (marked PUMP-N) (fig.1F) and brown (marked PUMP-L)(fig. 1G) if the boiler is equipped with a 230V circulation pump.
3. Release the white 6-point connection block (fig.1H) from the sensors on the printed circuit board.
4. Detach the white 4-point connection block (fig.1I) from the fan on the printed circuit board.
5. Detach the white 5-point connection block (fig.1J) from the solenoid valve on the printed circuit board.
6. Untighten the hex-screw on the printed circuit board (fig. 1K).
7. Remove the printed circuit board by pressing together the three hooks, (fig. 1L), and pulling out the circuit board.
8. Push the new circuit board firmly in and connect the cables as shown in fig. 1.
9. **NB!** Tighten the hex-screw holding the printed circuit board (fig 1K).
10. Refit the service panel and test-run the electrical heating cartridge.

NB! Caution! Take preventative measures against static electricity when handling the printed circuit board. Static can damage the PCB.

Fig 1.

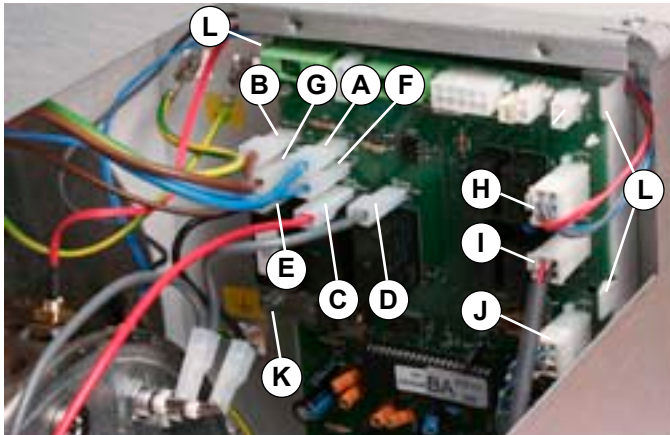

CABLE MARKINGS FIG.1

- 1A Blue cable, marked Blue on the printed circuit board.
- 1B Brown cable, marked Brown on the printed circuit board.
- 1C Red cable, marked Red on the printed circuit board.
- 1D Grey cable, marked Grey on the printed circuit board.
- 1E Black cable, marked Black on the printed circuit board.
- 1F Blue cable from pump marked, PUMP-N on the printed circuit board.
- 1G Brown cable from pump marked, PUMP-L on the printed circuit board
- 1H White 6-point connection block from the sensors.
- 1I White 4-point connection block from fan.
- 1J White 5-point connection block from solenoid.

3:2 REPLACING FAN

1. Remove the service panel on the boiler
2. Release the cable from the fan motor by lifting the hook (fig. 2A) and pulling the cable straight out.
3. Release the plastic housing from the motor, 2 screws (fig 2B).
4. Release the 4 plate screws (fig. 3A) securing the fan to the fan housing.
5. Lift the fan out of the boiler body.
6. Fit the new fan by following these instructions in reverse.

NB! Take care not to damage the impeller when fitting the fan.
7. Refit the service panel and test-run the boiler.

Fig 2.

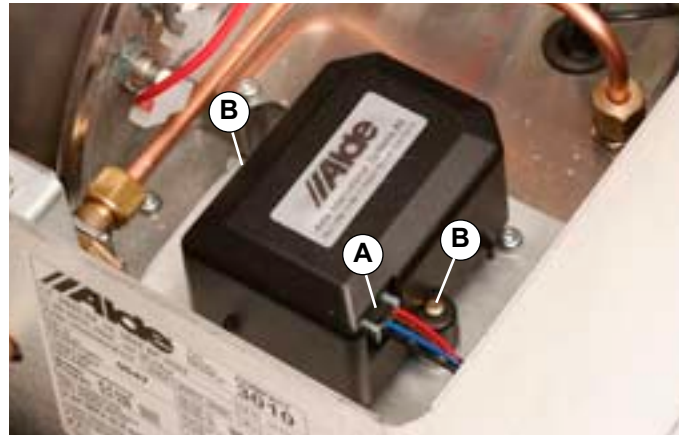
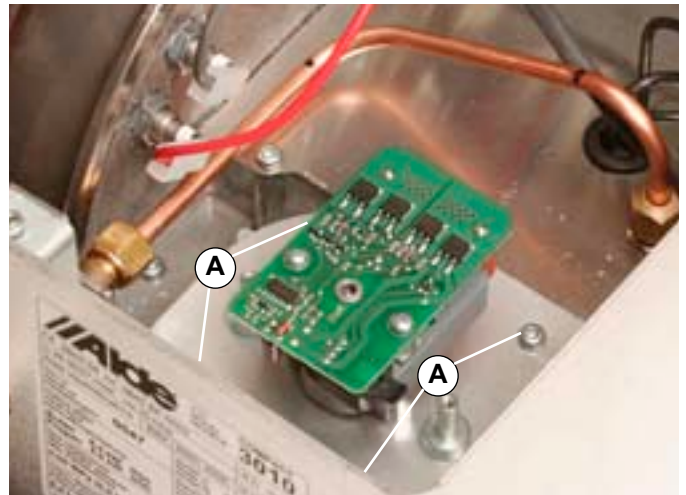

Fig 3.



3:3 REPLACING A BURNER

1. Remove the service panel on the boiler.
2. Release the fan in accordance with 3:2.
3. Remove the sensor cable (fig. 4A) and spark electrode cables (fig. 4B) from the printed circuit board.
4. Using two spanners, unscrew the gas pipe from the burner (fig. 4C) and the solenoid valve (fig. 7B).
5. Remove the three screws (fig. 4D) on the end plate of the burner against the burner housing.
6. Pull the end plate with burner straight out of the burner housing (see fig. 5).
7. Fit the new burner following the instructions in the reverse order.
8. Using two spanners, tighten the nuts on the solenoid valve and on the burner to 7-9 Nm.
Remember to check that the cones are correctly fitted to the pipe.
- NB!** Check the system and connections for leaks with leak detector spray when the boiler is running.
9. Connect flame sensor cables and spark electrode cables to the printed circuit board.
10. Refit the service panel and test run the boiler.

Fig 4.

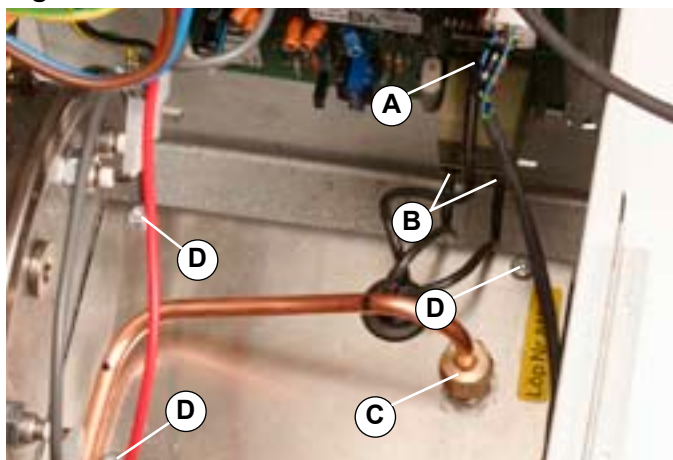
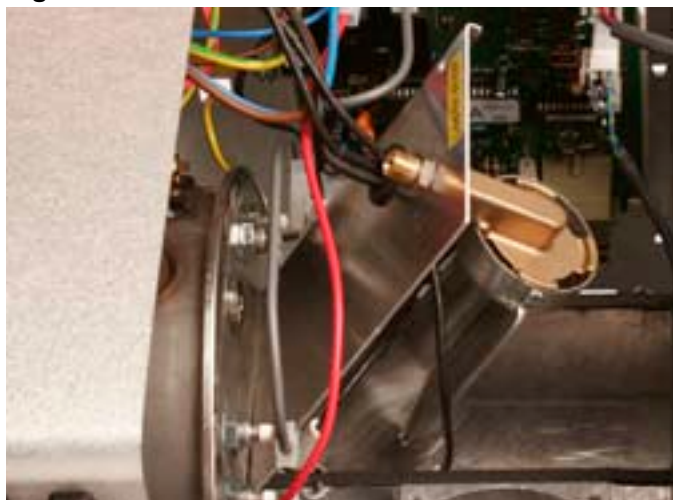

Fig 5.



3:4 REPLACING SPARK ELECTRODE

When replacing the spark electrode, also replace the flame sensor.

1. Detach the burner as per instructions in 3:3.
2. Release the screws (fig. 6A) and remove the spark electrode (fig. 6B).
3. Fit the new electrode, and secure it. Check that the distance between the points on the spark electrode is 2.5-3.5mm, and that this is correctly positioned.
4. Refit the burner according to 3.3, and test-start the boiler.

3:5 REPLACING THE FLAME SENSOR

When replacing the flame sensor also replace the spark electrode.

1. Detach the burner in accordance with 3:3.
2. Release the screws (fig. 6 C) and remove the flame sensor (fig. 6 D).
3. Fit the new flame sensor, ensuring that the tip of the flame sensor is positioned above the burner in accordance with fig. 6., and secure.
4. Fit the burner in accordance with 3:3 and test-start the boiler.

Fig 6.

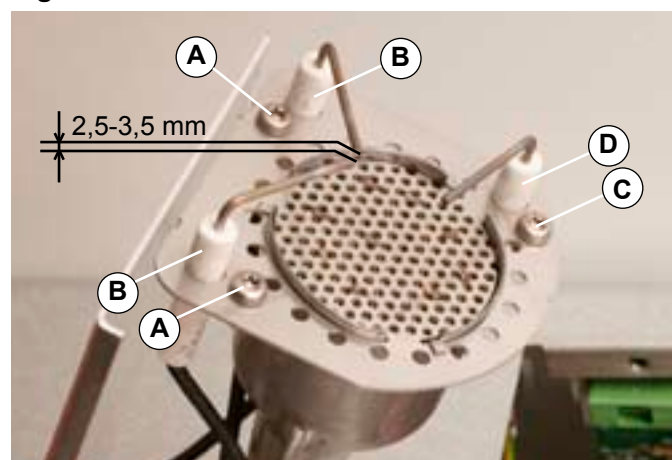

3:6 REPLACING THE SOLENOID VALVE

1. Remove the service panel on the boiler.
2. Release the connection block (fig. 1J) from the printed circuit board.
3. Unscrew the gas pipe (using two spanners) from the burner (fig. 7A) and the solenoid valve (fig. 7B).
4. Release the 3 screws (fig. 8A) from the solenoid valve attachment.
5. If necessary, the outer coil can be unscrewed in order to make it easier to remove the solenoid valve. Unscrew the nut (fig. 8B). Remove the plate over the coil (fig. 8C) and lift off the top coil (fig. 9A) from the solenoid valve.
6. Lift up the solenoid valve and refit the new one in reverse order. Check that the cable to the upper coil fits correctly in the groove in the plate (fig. 9B).
7. Tighten the nuts (using two spanners) to the solenoid valve (fig. 7B) and to the burner (fig. 7A), to 7-9Nm. Do not forget to check that the cones are correctly fitted on the pipe. Check the system and the connections for leaks with leak detector spray when the boiler is running.
8. Refit the service panel.

Fig 7.

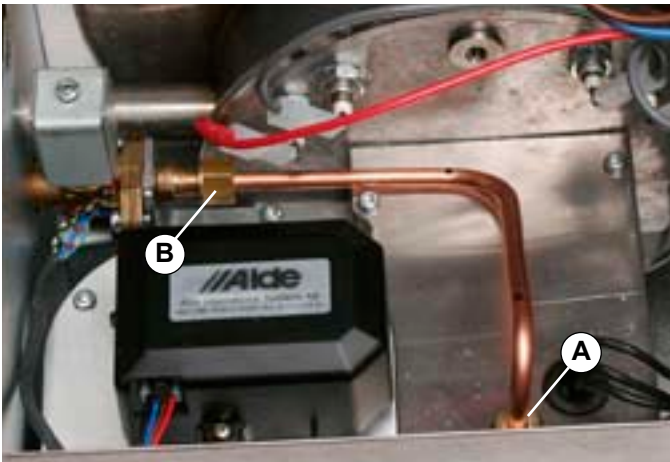
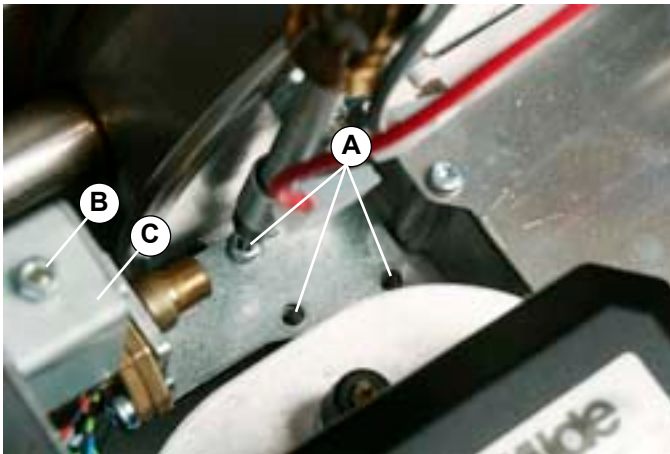

Fig 8.



3:7 REPLACING THE SENSOR

1. Remove the service panel on the boiler.
2. Release the 6-point connection block (fig. 10A) from the printed circuit board.
3. Release the connection cables from their groove (fig. 10B) on the printed circuit board attachment.
4. Remove the brass screws from the operating thermostat (blue cable) (fig. 11B) and overheating protection (red cable) (fig. 11A) from the boiler body.
5. Lift the hot water thermostat bracket (grey cable) (fig. 11C) from the boiler body.
6. Remove the sensors together.
7. Refit the sensors in reverse order.
8. Refit the service panel and test run the boiler.

Fig 9.

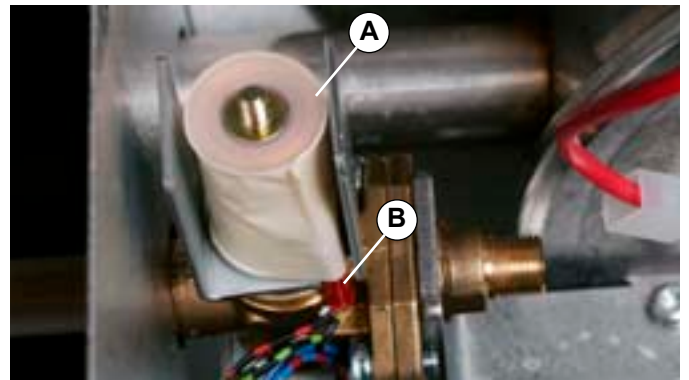

Fig 10.

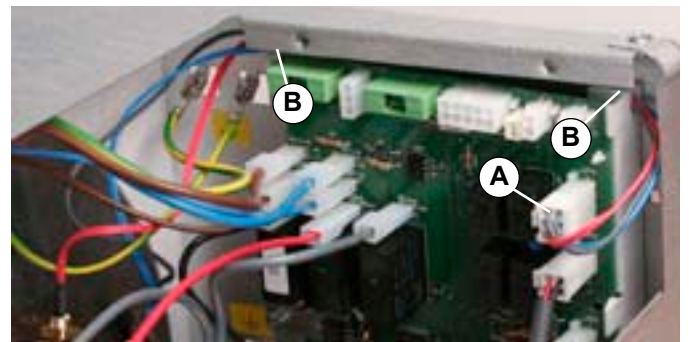
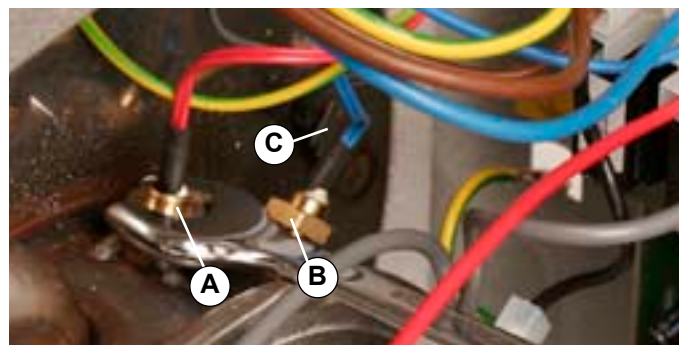

Fig 11.



4:0 FAULT MESSAGES IN THE PANEL

NB! Fault messages are only shown when the panel is idle GAS OUT is reset by the main breaker being switched off and switched on again.

Otherwise, it is reset through the 12-volt main breaker being switched off and then being switched on again.

GAS OUT

Caused by:

The heater has attempted to light the boiler repeatedly, without the electronics receiving the signal from the sensor that monitors the flame.

Probable reasons for the fault:

- No gas supply or insufficient gas supply in the vehicle.
- The electronics do not send a signal to the gas valve.
- The gas valve does not open.
- Impurities in the heater's gas pipes or nozzle.
- No spark from the electronics.
- The spark electrode has been damaged or is incorrectly mounted.
- The sensor circuit in the electronics is not working.
- The sensor has been damaged or is incorrectly mounted.
- The exhaust/intake hoses have been damaged or are incorrectly mounted.
- Insufficient battery voltage or contact fault in cable.
- Break/short circuit in sensor no. 2 (red cable).

OHEAT 1

Caused by:

The blue sensor on the boiler body has registered a temperature in excess of 100°C, or break/short circuit.

Probable reasons for the fault:

- Air in the heating system.
- Insufficient circulation or pump not working.
- The sensor has been damaged.
- The electronics are not monitoring the temperature.

OHEAT 2

Caused by:

The red sensor on the boiler body has registered a temperature in excess of 100°C, or break/short circuit.

Probable reasons for the fault:

- See OHEAT 1.

FA

Caused by:

The fan has incorrect speed or is not in contact with the electronics.

Probable reasons for the fault:

- Fault in the fan.
- Break in the wiring between fan and printed circuit board.
- Monitoring by the printed circuit board not working.

BATT LO

Caused by:

The vehicle's battery voltage is less than 10.5 volts.

Probable reasons for the fault:

- Battery is low.
- Faulty contact between cable and boiler.
- Heater taking abnormally high current.
- Fault in printed circuit board.

WINDO

Caused by:

Connection no. 4 in the panel's accessory block is broken. When this is broken, the heater does not function with LPG. Usually this function is used to break the LPG heat if a window is opened that is mounted close to the wall flue. If the function is not used, a loop shall be mounted on the panel.

Probable reasons for the fault:

- Break in connection between switch and panel.
- Window switch damaged or incorrectly mounted.
- The loop incorrectly mounted or not present.

SERIAL

Caused by:

Communication fault between boiler and panel.

Probable reasons for the fault:

- Break in the cable for data communication between heater and panel.
- Ignition spark goes to earth and interrupts communication.
- Some other electrical apparatus is interrupting communication.

OTHER FAULTS THAT ARE NOT INDICATED IN THE PANEL.

The heater is completely inactive and the panel is not lit up.

- One of the 12-volt fuses has blown.
- The safety fuse has blown.

No electrical power.

- The 230 volts is not connected, or a fuse has blown.
- One of the 230-volt relays is not working.
- Break/short circuit in sensor no. 2 (red cable)

No heating in the vehicle despite the fact that the panel is correctly installed.

- One of the circulation pumps is not working.
- Air in the heating system.

Incorrect heat regulation.

- The panel or remote sensor is unsuitably located.

No warm water.

- Problem with hot water thermostat (grey cable).
- PE on the panel in position ON.

5:0 SAFETY CHECKS

Safety checks shall be carried out after each service.

Check:

- That the intake/exhaust gas hoses and roof flue do not leak and are not damaged.
- That the LPG connections do not leak. Check the system for leaks.
- That the 230V ~ earth connection is connected.
- That the safety valve on the warm water heater has not been displaced.
- That the heating system has been filled with glycol mixture up to the mark on the expansion vessel.

6:0 EXPLODED DIAGRAM

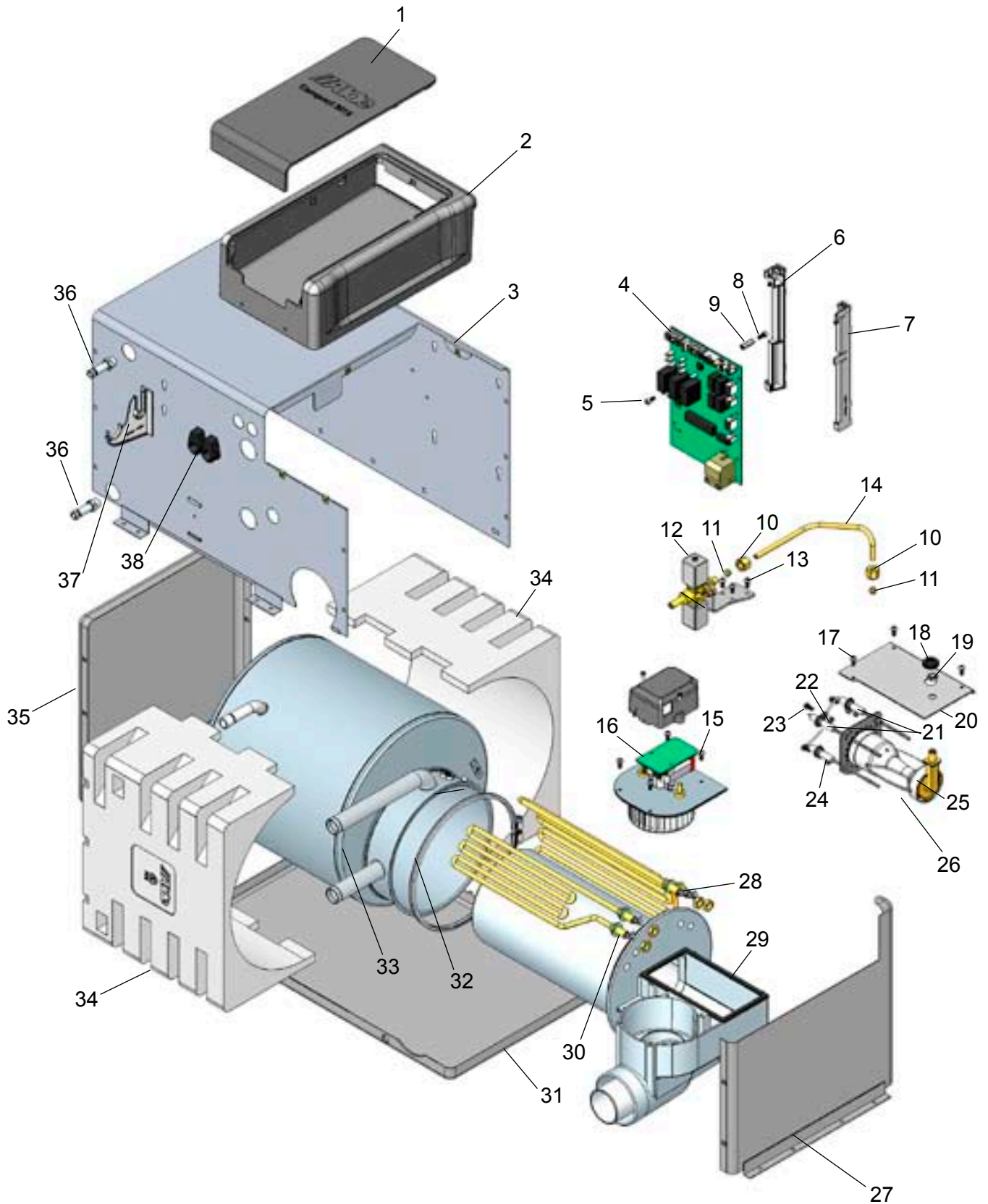

6:1 ARTICLE NUMBERS ON EXPLODED DIAGRAM (FOR SPARE PARTS, SEE PAGE 13)

- | | | | |
|---------------------|--------------------------------------|---------------------|-----------------------------------|
| 1. 3010 149 | Service cover | 21. 3010 133 | Spark electrode |
| 2. 3010 148 | Service panel | 22. 3010 186 | Nut |
| 3. 3010 152 | Cover | 23. 3010 181 | Screw |
| 4. 3010 302 | Printed circuit board 2 kW | 24. 3010 134 | Flame sensor |
| 3010 303 | Printed circuit board 3 kW | 25. 3010 122 | Burner |
| 5. 3010 187 | Screw | 26. 3010 301 | Burner compl. |
| 6. 3010 189 | Printed circuit board bracket, left | 27. 3010 150 | End, front |
| 7. 3010 188 | Printed circuit board bracket, right | 28. 3010 141 | Electrical heating cartridge, 2kW |
| 8. 3010 181 | Screw | 29. 3010 136 | Gasket |
| 9. 3010 178 | Spacer | 30. 3000 140 | Electrical heating cartridge, 1kW |
| 10. 3010 163 | Nut | 31. 3010 153 | Bottom plate |
| 11. 3010 164 | Cone | 32. 3010 200 | Clamping ring |
| 12. 3010 304 | Solenoid valve | 33. 3010 110 | Boiler body |
| 13. 3010 182 | Screw | 34. 3010 158 | Insulation |
| 14. 3010 312 | Copper pipe | 35. 3010 151 | End, back |
| 15. 3010 182 | Screw | 36. 3000 472 | Nipple |
| 16. 3000 452 | Fan compl. | 37. 3010 159 | Support for back valve |
| 17. 3010 182 | Screw | 38. 2762 125 | Draught vent |
| 18. 2930 235 | Cable entry | | |
| 19. 3010 166 | Nut | Other parts | |
| 20. 3010 135 | Plate | 3010 305 | Sensor set |
| | | 3010 205 | Cable to fan |

7:0 WIRING DIAGRAM WITH CONTROL PANEL

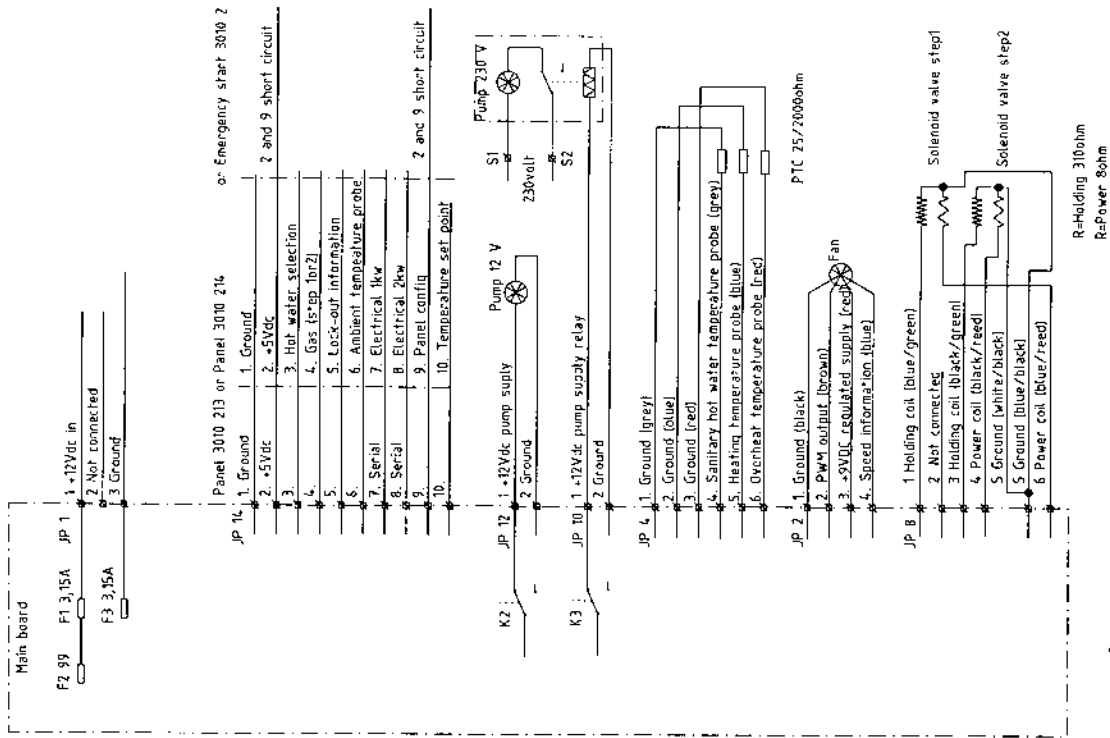

Kretschema 3010 051006 LT

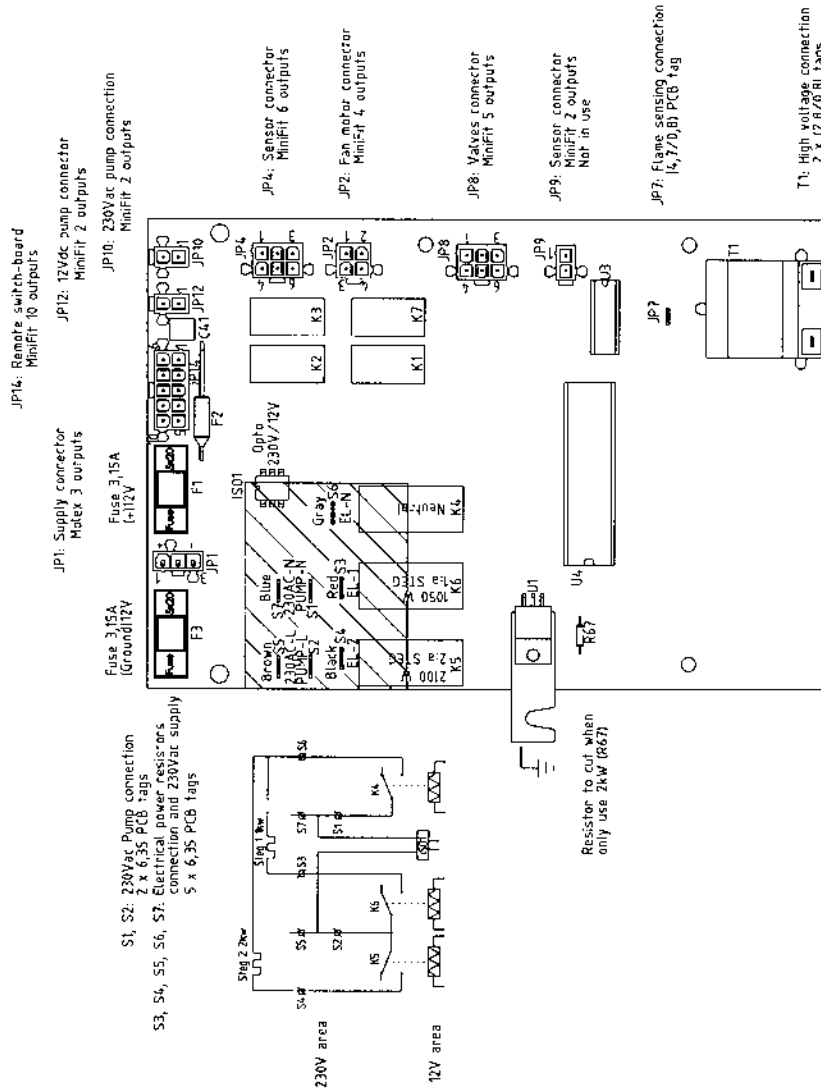

8:0 SPARE PARTS



1. **3000 452** Fan compl.

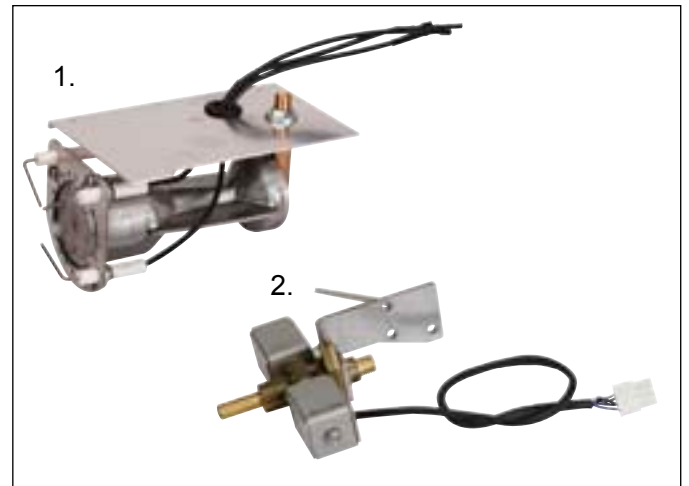

1. **3010 301** Burner compl.
2. **3010 304** Solenoid valve compl.



1. **3010 302** Printed circuit board, 2kW
2. **3010 303** Printed circuit board, 3kW

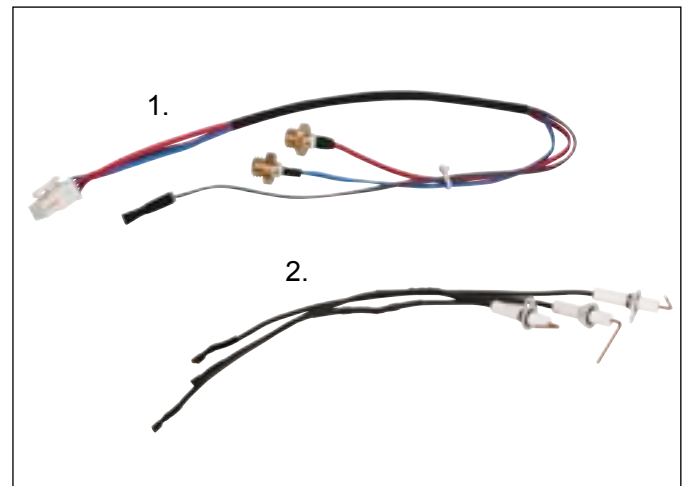

1. **3010 305** Sensor set compl.
2. **3010 306** Spark electrode/Flame sensor



Alde International Systems AB

Wrangels allé 90 • Box 11066 • S-291 11 Färlöv • Sweden
Tel +46 (0)44 712 70 • Fax +46 (0)44 718 48 • www.alde.se • info@alde.se